

## Design Release

Date: November 1, 2024

Reference: Design Improvement

Product Line: CYCLEMASTER® Ball Valves with access port

In an effort to supply customers with the most meaningful and practical refrigeration and air conditioning component product designs, Mueller Refrigeration will transition to a unibody design of their CYCLEMASTER® Ball Valves. The enhanced design features include:

- Robust body incorporates access port for increased working pressures
- Minimized joints decreasing leak potential
- Increased product flexibility for various tube configurations and materials
- Improved serviceability with easy-to-reach access port
- Durable all brass forging construction
- Compact, efficient design

### Previous Design

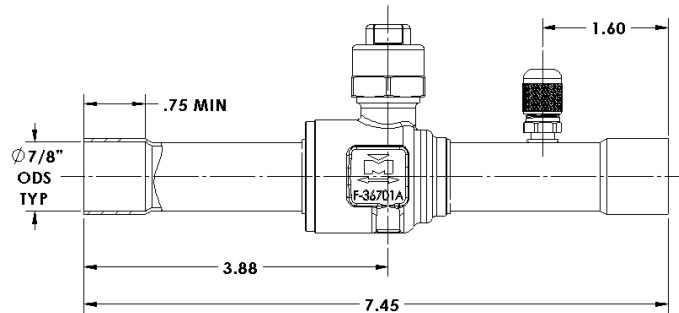
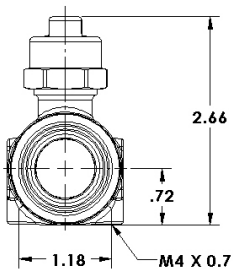

### Redesigned

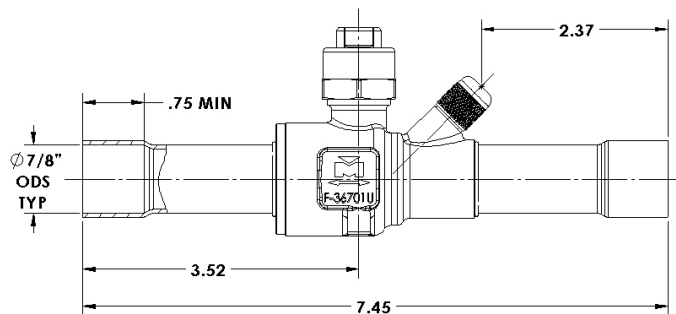
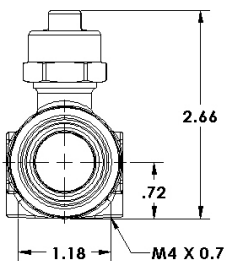

CYCLEMASTER® Ball Valves are UL/cUL Listed, conform to the Pressure Equipment Directive 2014/68/EU.

The new unibody design will be released in phases by valve size and there will not be a change of part numbers. All inventories will be depleted of the previous design before the redesigned product will be shipped. Inventory for AQ17864C (7/8") is expected to transition in Q1 2025.

For specific application questions or assistance with product selections, please contact your local Mueller Refrigeration sales representative or authorized distributor.