



CYCLEMASTER® BALL VALVES

SERIES 4R SPRING RETURN ACTUATOR

INSTALLATION INSTRUCTIONS

NOTE: These instructions cover multiple kits. Use the instruction section(s) that applies to the kit being installed.

ACTUATOR/HUB REMOVAL

1. Disconnect Actuator (10) from all electrical sources.
2. Remove Actuator from Sealed Hub Stem (3) by:
 - a) Loosen the three Shaft Adapter screws (Fig. 3).
 - b) Loosen and remove the Shoulder Screw (11) and Locknut (12).
 - c) Lift the Actuator (10) off the Stem and Hub Mounting Plate (8).
3. Remove Hub Assembly (2-7) from Ball Valve (1) by:
 - a) Remove Hex Head Bolts (9) from Hub (6). Lift Actuator Mounting Plate (8) off Hub.
 - b) Loosen the Set-Screws (7) on Hub (6).
 - c) Remove Hub by placing wrench on flats of the Sealing Mechanism (5) and turn counter-clockwise.
 - d) Unscrew Hub Assembly from valve.

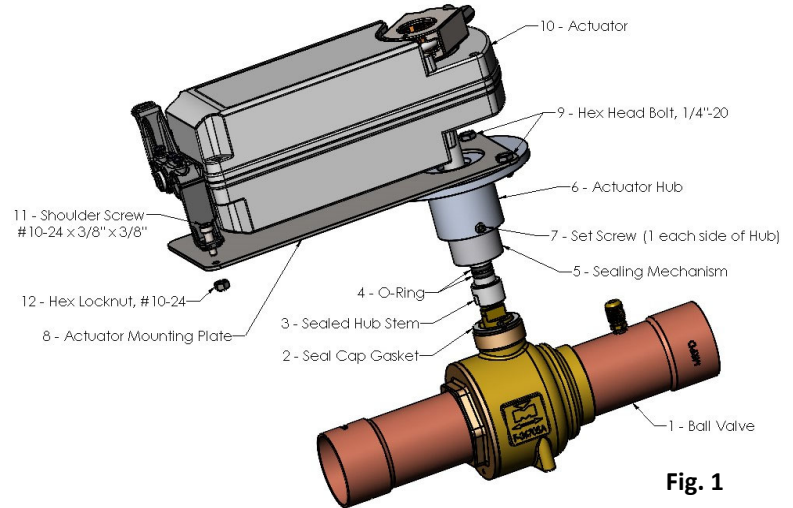

Fig. 1

HUB INSTALLATION

1. Remove Sealing Mechanism (5) from Hub Assembly (2-7).
2. Ensure top of the Ball Valve neck(1) brass sealing surface is clean and free of debris.
3. Place Seal Cap Gasket (2) on sealing surface of Sealing Mechanism (5) where it will be located between the sealing mechanism and the top of the valve neck (see Fig. 1).
4. Apply a small amount of thread sealant to the threads of the sealing mechanism then thread the sealing mechanism into Hub (6) with the wrench flats toward the flange. Thread far enough into the hub so that the wrench flats of sealing mechanism are accessible above the hub flange.
5. Partially install the Set Screws (7) into the Hub.
6. Ensure O-Rings (4) and Stem (3) grooves are well lubricated with Dow #111 or equivalent.
7. Align slot in the Sealed Hub Stem (3) with valve stem (see Fig. 1). Slide Hub with Sealing Mechanism down over Stem, and thread hub onto valve neck as far as possible, stopping just before bottoming out.
8. Align Hub so that Actuator (10) will be in the desired orientation (see Fig. 1). With Allen wrench, tighten Set Screws (7). Torque 60-65 lb-in on either side of Hub until Hub is secured against the Ball Valve body to avoid rotation during operation.
9. While holding to proper orientation, continue to tighten Sealing Mechanism with wrench to snug, then approximately ¼ to ½ more turns, to ensure tight seal of the gasket against valve body. Pull Stem (3) upward while tightening the Sealing Mechanism, away from Ball Valve, to remove any slack in the assembly.

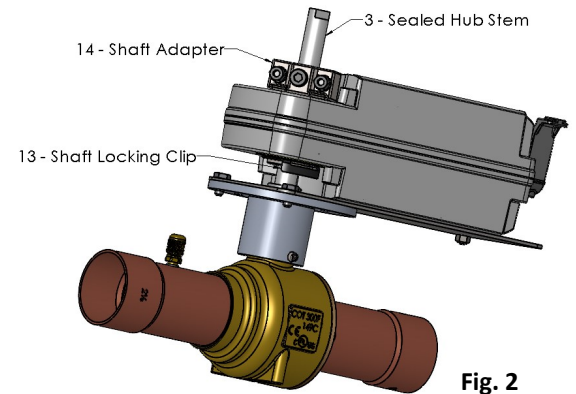

Fig. 2

ACTUATOR INSTALLATION

1. Attach the Actuator Mounting Plate (8) to Hub (6) using the two Hex Head Bolts (9). Tighten bolts 70-80 lb.-in. See Fig. 1 for orientation of plate.
2. Determine whether the fail-safe (loss of power) position required for the valve is open or closed. The side of the Actuator (10) facing upward will determine the rotation direction of the actuator and therefore whether the valve is opened or closed upon loss of power. This is changed by removing the Shaft Locking Clip (13)(Fig. 2), reversing the Shaft Adapter (14) and replacing the Clip. On the label near the shaft adapter is a diagram showing direction of rotation for powered operation, the number "1", and spring return rotation direction, the number "0" (power loss). For valve closed upon power loss, position the actuator arm fully counter clockwise, making sure the valve is fully closed. For valve open upon power loss, position the actuator arm fully clockwise, making sure the valve is fully open. The valve and actuator arm MUST be matched for proper function.
3. After the Actuator (10) and Valve (1) are placed in proper positions, place the Actuator over the Stem (3), onto the Actuator Mounting Plate (8), with the bottom of actuator flush on the plate. Insert Shoulder Screw (11) through leg at rear of Actuator (10), through hole in plate, and attach with Hex Locknut (12), without tightening nut completely (see Fig. 1).
4. Pull Stem (3) upwards, away from Ball Valve (1) until no additional space is between the Hub Assembly's Stem and Sealing Mechanism.
5. While holding Actuator (10) flush against Actuator Mounting Plate (8), tighten Shaft Adapter Centering Screw (15)(Fig. 3). Tighten both Shaft Clamp Screws (16). Torque: 97-115 lb.-in. (11-13 N-m). Fully tighten Hex Locknut (12) See Commissioning Instructions.

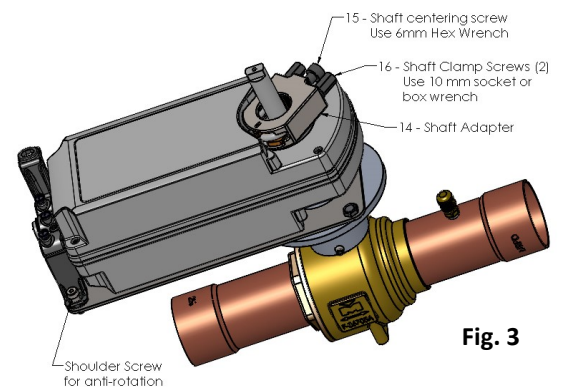









Fig. 3

Actuator Features:

- Brushless DC motor technology with stall protection
- Bi-directional fail-safe spring return
- Fast acting, 30 sec. full open, 15 sec. full closed
- cUL and UL Listed, CE Certified

Service Warnings/Cautions

	DO NOT OPEN THE ACTUATOR. IF THE ACTUATOR IS INOPERATIVE, REPLACE THE UNIT.
	Do not wire different types of actuators in parallel with these models.
	Installations requiring CE Conformance: All wiring for CE certified actuators must only be separated extra low voltage (SELV) or protective extra low voltage (PELV) per HD384-4-41. Use safety isolating transformers (Class III transformer) per EN61558. They must be rated for 100% duty cycle. Overcurrent protection for supply lines is maximum 10A.
	Personal injury/loss of life may occur if a procedure is not performed as specified.
	Not for use in condensing or wet applications.
	Equipment damage or loss of data may occur if the user does not follow a procedure as specified.
	To avoid injury or loss of life, pay attention to any hazardous voltage when performing checks.

Wiring

All wiring must conform to NEC and local codes and regulations.

Use earth ground isolating step-down Class 2 transformers. Do not use auto transformers.

The sum of the VA ratings of all actuators and all other components powered by one transformer must not exceed the rating of the transformer. It is recommended that one transformer power no more than 10 actuators.

Standard Symbol	Function	Terminal Designation	Series I Color
1	Supply (SP)	G	Red
2	Neutral (SN)	G0	Black
3	Ground	GND	Green/Yellow

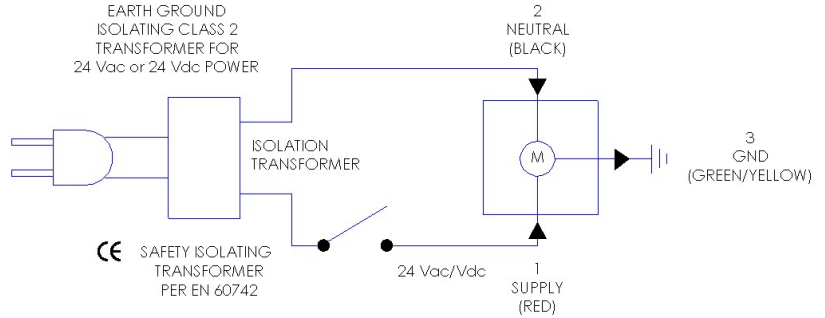

START UP/COMMISSIONING

NOTE: The intended function of the Actuator and Ball Valve is to provide a “fail-safe” position for the valve upon loss of power, using an internal spring return.

Verification of Actuator Function

1. With the Actuator not mounted to the ball valve, check that the wires are connected correctly. Wire 1 (red) and 2 (black) to 24 Vac or 24 Vdc power supply; Wire 3 (Green/Yellow) to ground.
2. Apply power and allow the actuator shaft coupling to rotate from 0° to 90°. Disconnect wire 1 (red) and the shaft coupling should return to the “0” position.
3. Check the spring return by reconnecting wire 1 (red). Allow the shaft coupling to rotate halfway, then disconnect wire 1 (red), and the shaft coupling should return to the “0” position.

Verification of Valve and Actuator Function

1. Mount the Actuator on the Ball Valve, using the installation instructions. The valve is to be fully open or closed, depending on the desired “fail-safe” position, which is the spring return, or unpowered, position. The label on the Actuator indicates which side of the actuator needs to face “up” for the desired spring return and powered rotation directions.
2. Once the Actuator is securely mounted to the Ball Valve, connect the power wires; wire 1 (red) and wire 2 (black) to 24 Vac or 24 Vdc power supply.
3. Apply power and allow the Actuator shaft coupling to rotate 90°. This should fully open or fully close the valve. If the valve does not rotate the full 90°, verify the shaft coupling is fully tightened to the Hub Shaft, and that the Hub Shaft is engaged with the Ball Valve Shaft. After 90° rotation is achieved, disconnect wire 1 (red) from the power supply. The actuator and valve should then return to the starting position (fail-safe).
4. To further test the Spring Return function, re-connect wire 1 (red) and apply power. Allow the Actuator Shaft Coupling to rotate halfway, then disconnect wire 1 (red). The actuator shaft coupling should then return to the starting position (fail-safe), and the valve should be fully open or fully closed.

Specifications: Series 4R Spring Return Actuator for Ball Valve Size 2 1/8"	
Power Supply	Operating Voltage: 24 Vac ±20%
	Frequency: 50/60 Hz
Equipment Rating	Power Consumption: Run/Hold: 33 VA/9 VA
	Rating: Class 2 in accordance with UL/CSA; Class III per IEC 60536
Function	Bi-directional spring return actuator motor. Returns to fail safe position upon loss of power.
	Running/Spring Return Torque: 200 lb.-in (9 Nm). Stall Torque (minimum): 280 lb-in (32 Nm)
	Runtime for 90° Opening— Powered: 30 sec.; Closing—Spring Return (loss of power): 15 sec.
	Nominal Angle of Rotation: 90°
	Maximum Angular Rotation: 95°
Housing	Enclosure: NEMA 1; IP40
	Material: Plenum rated rugged plastic
	Gear Lubrication: Silicone free
Ambient Conditions	Actuator Operation Temp: 0°F to 140°F (-18°C to 60°C). One time 350° F (177° C) 1/2 hour per UL555S
	Storage and Transport Temperature: -40°F to 158°F (-40°C to 70°C)
	Ambient Humidity (non-condensing): 95% rh
Agency Certification	UL Listing: UL60730
	Canadian Conformance: cUL CSA 60730
Conformity	CE conformity for residential, commercial, and industrial environments
	Australian RCM conformity
Miscellaneous	Pre-Cabled Connection: 18 AWG
	Cable Length: 3 feet (0.9 m)
	Life Expectancy: 20,000 Full Strokes at rated torque and temperature.
	Dimensions: 1.7" L x 3.4" W x 3.8" D (272.8 mm L x 101.5 mm W x 96.4mm D)
	Weight: 9 lb. (4.1 kg)
Operation	When operating voltage is supplied, the actuator rotates from 0° to 90°. The actuator is reversible, and the direction of rotation depends on how the actuator is mounted, which determines whether the ball valve is opened or closed when powered. On power failure or when the operating voltage is switched off, the spring return moves the actuator to its mechanical starting position. The information label on the actuator shows the rotation direction for powered and spring return operation, depending on mounting.