



MUELLER REFRIGERATION, LLC
121 Rogers Street
Hartsville, TN 37074
P 615.374.2124

Design Release

Date: January 8, 2021

Reference: Design Improvement

Product Line: Four-Bolt Check Valves

In response to evolving market demands requiring refrigeration and air conditioning components become more seamlessly integrated into new space saving equipment designs while improving overall performance and functionality, Mueller Refrigeration has enhanced the design of select CHECKMASTER® Four-Bolt Check Valves to meet these industry challenges.

Using the latest computer-aided engineering design modeling and analysis software, Mueller Refrigeration has been able to reduce the overall footprint, while maintaining critical dimensions such as overall lengths for ease of installation and replacement. Additionally, an o-ring is added for improved sealing.

CYCLEMASTER® series valves are UL and CE Recognized and have been extensively tested and rated for use with all refrigerants and oils including systems that incorporate higher- pressure refrigerants such as R-410a and subcritical CO₂.

General dimensional information can be found in the overview below.

Previous Design

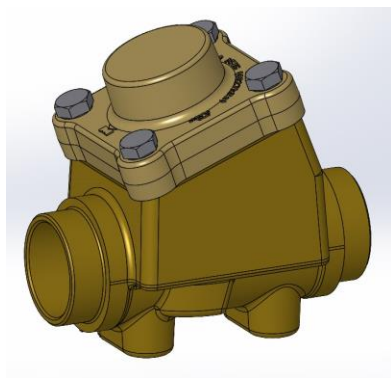

Q2 2021 Redesign

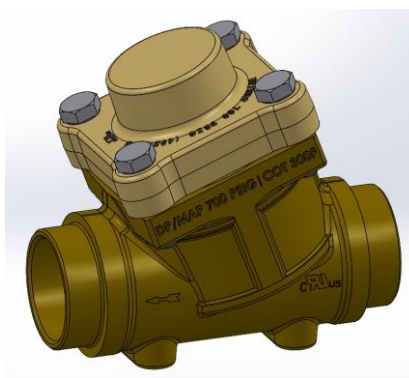



MUELLER REFRIGERATION, LLC

121 Rogers Street
 Hartsville, TN 37074
 P 615.374.2124

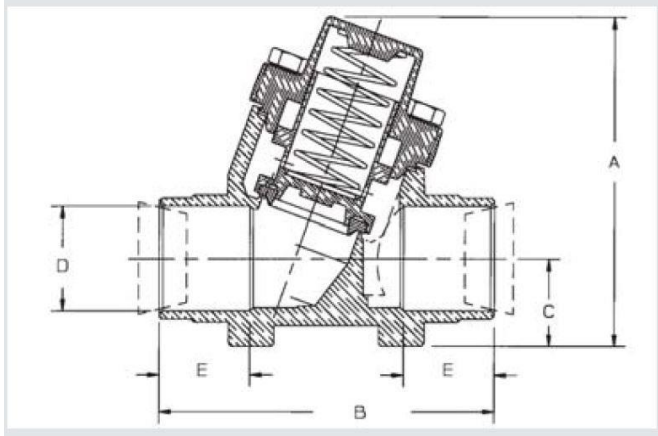

Dimensional changes to Four-Bolt Check Valves

	A		C		Wt.	
	in	mm	in	mm	lb	kg
NEW						
B 34237	4.39	112	1.1	28	4.14	1.88
B 34238	4.39	112	1.1	28	4.19	1.9

	A		C		Wt.	
	in	mm	in	mm	lb	kg
CURRENT						
B 34237	4.53	115	1.25	32	5.14	2.33
B 34238	4.53	115	1.25	32	5.2	2.36

For specific application questions or assistance with product selections, please contact your local Mueller Refrigeration sales representative or authorized distributor.