

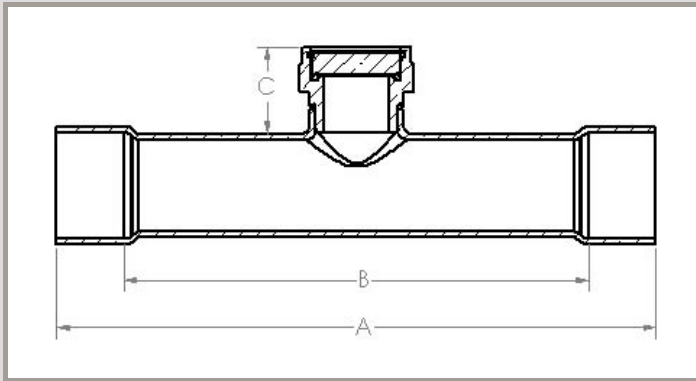

Features:

- Maximum abnormal pressure (MAP): charted below
- Continuous operating temperature (COT): -40°F/185°F, -40°C/85°C
- Compatible with all CFC, HCFC and HFC refrigerants and oils
- UL/cUL Recognized, Conforms to Pressure Equipment Directive 2014/68/EU
- Designed for maximum flow and minimum pressure drop
- Large viewing window and indicator for better visibility
- Provides accurate identification of system conditions



Part Number	Size		A		B		C		MAP		Wt	
	in	mm	in	mm	in	mm	in	mm	psi	bar	lb	kg
A 18120	1 1/8	29	6.30	160	4.49	114	0.98	25	700	48	0.59	0.27
A 18121	1 3/8	35	7.87	200	5.95	151	0.98	25	700	48	0.75	0.34
A 18122	1 5/8	41	7.87	200	5.71	145	0.98	25	700	48	1.01	0.46
A 18123	2 1/8	54	7.87	200	5.20	132	0.98	25	650	45	1.40	0.64

Moisture Content PPM

HFC and HCFC Refrigerants	75°F Liquid Refrigerant		100°F Liquid Refrigerant	
	Green/Dry	Yellow/Wet	Green/Dry	Yellow/Wet
R12	5	20	10	35
R22	30	125	45	185
R134a	25	110	45	175
R404A	20	75	25	130
R407C	30	145	55	230
R410a	25	165	45	300
R502	10	45	20	65
R507	15	75	30	140