

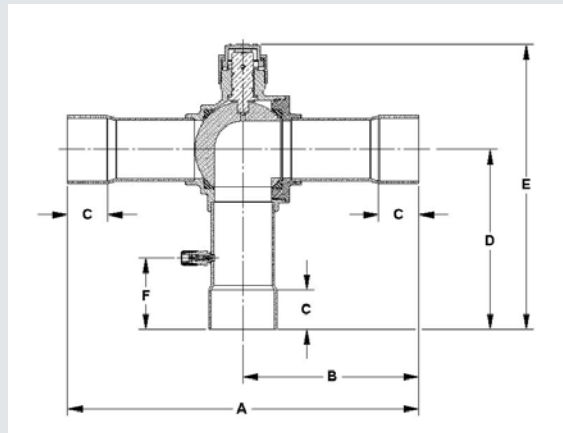

Características:

- Presión de operación máxima (MAP): 700 psig, 48 bar
- Rango de temperatura de operación (COT): -40°F/300°F, -40°C/149°C
- Compatible con todos los refrigerantes y aceites CFC, HCFC y HFC
- Construcción completa del puerto para que corresponda al tamaño del diámetro interno de la tubería
- Diseño redondo internamente balanceado
- Vástago encapsulado a prueba de roturas
- Tecnología de sellado MCM
- Aparece en la lista de UL/cUL, se adhiere a la norma 2014/68/EU relativa a equipos de presión.



Número de pieza	Tamaño		Cv	Kv	A		B		C		D		E		F		Puerto (in)	Peso		kit tapa del sello
	in	mm			in	mm	in	mm	in	mm	in	mm	in	mm	in	mm		lb	kg	
AU17860	3/8	10	2.23	2	5.50	140	2.97	75	0.31	8	2.61	66	4.16	106	1.16	29	0.50	0.73	0.33	A 17842
AU17861	1/2	13	3.94	3	6.38	162	3.42	87	0.38	10	3.05	77	4.60	117	1.21	31	0.50	0.74	0.33	A 17842
AU17862	5/8	17	4.63	4	6.38	162	3.42	87	0.50	13	3.05	77	4.60	117	1.35	34	0.50	0.74	0.34	A 17842
AU17863	3/4	19	11.90	10	7.47	190	3.91	99	0.62	16	3.65	93	5.86	149	1.47	37	0.75	1.40	0.64	A 17843
AU17864	7/8	22	10.89	9	7.47	190	3.91	99	0.75	19	3.65	93	5.86	149	1.60	41	0.75	1.52	0.69	A 17843
AU17865	1 1/8	29	19.33	17	8.41	214	4.33	110	0.91	23	4.01	102	6.39	162	1.74	44	1.00	2.82	1.28	A 17844
A 17545	1 3/8	35	31.06	27	10.00	254	5.07	129	0.97	25	4.92	125	7.89	200	2.04	52	1.25	4.97	2.25	A 17845
A 17546	1 5/8	41	44.69	39	11.00	279	5.53	140	1.09	28	5.46	139	8.61	219	2.25	57	1.50	7.17	3.25	A 17845
AU17868	2 1/8	54	76.32	66	11.86	301	5.95	151	1.34	34	6.06	154	9.58	243	2.41	61	1.93	8.27	3.75	A 17845
AU17871 *	2 5/8	67	69.85	60	11.90	302	5.97	152	1.47	37	6.08	154	9.60	244	2.48	63	1.93	8.80	3.99	A 17845

* Puerto reducido