

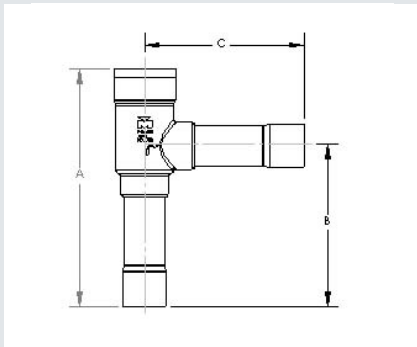

Features:

- Design Pressure (DP) / Maximum abnormal pressure (MAP): 700 psig, 48 bar
- Continuous operating temperature (COT): -40°F/300°F, -40°C/149°C
- Contact factory or visit website for compatibility with CFC, HCFC, HFC and HFO refrigerants and oils
- UL/cUL Recognized, Conforms to Pressure Equipment Directive 2014/68/EU
- 100% tested
- Forged brass body exceeds the most stringent quality standards in the industry
- Neoprene gasket



Part Number	Size (in)		Cv	Kv	A		B		C		Wt	
					in	mm	in	mm	in	mm	lb	kg
A 18383C	7/8	Male Inlet x Female Outlet	13.4	11.6	5.38	137	3.70	94	3.47	88	0.81	0.37
A 18565C	7/8	Male Inlet x Male Outlet	13.4	11.6	5.38	137	3.70	94	3.67	93	0.81	0.37
A 18566C	* 7/8	Female Inlet x Female Outlet	13.4	11.6	5.18	132	3.50	89	3.47	88	0.81	0.37
A 18659C	* 1 1/8	Female Inlet x Female Outlet	30.2	26.1	8.02	204	5.55	141	4.84	123	1.93	0.88
A 18660C	* 1 3/8	Female Inlet x Female Outlet	37.0	32.0	8.02	204	5.55	141	4.84	123	1.98	0.90